

8010JC

BILOBA®

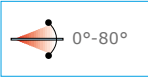

• Cerniera oleodinamica con regolazione delle velocità di chiusura dell'anta e **regolazione del punto 0**. Corpo interno anodizzato, ossidazione profonda (20 micron) e copertina esterna in acciaio inox AISI 316. Stop a 0° +90° -90°.

• Bisagra cierra puerta hidráulica con ajuste de velocidad de cierre de la puerta y **ajuste del punto 0°**. Cuerpo interior anodizado con tratamiento de oxidación con alto espesor (20 micron) y tapa exterior en acero inox AISI 316. Freno a 0°, + 90°, -90°.

• Hydraulic hinge with adjustment of the closing speed of the door and **zero point adjustability**. Inner body is anodized with the special deep oxidation (20 micron) and cover made of stainless steel AISI 316. Stop at 0° +90° -90°.

• Hydraulischcharnier mit Feststellung der Türschließgeschwindigkeit und **0°-Punkt-Regulierung**. Der innere Körper ist eloxiert mit Die Sonderoxydationsbehandlung (20 Mikron). Abdeckungen aus Edelstahl AISI 316. Feststellung bei 0° +90° -90°.

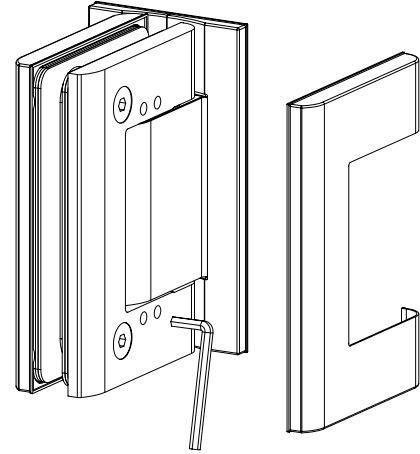

ATTENZIONE - PRECAUCIÓN - CAUTION - ACHTUNG
 APERTURE VIOLENTE OLTRE I 95° POTREBBERO CAUSARE LO SCARDINAMENTO. È CONSIGLIABILE L'APPLICAZIONE DI UN FERMAPORTA - APERTURA VIOLENTE ADEMÁS DE 95°, PODRIA CAUSAR DAÑO. ACONSEJAMOS UTILIZAR UN FIJA PUERTA. - VIOLENT OPENING FURTHER THAN 95° COULD UNHINGE THE DOOR. WE SUGGEST TO INSTALL A DOOR STOP - HEFTIGE ÖFFNUNGEN MEHR ALS 95° KÖNNTEN DIE TÜR AUSHEBEN. WIRSCHLAGEN DIE INSTALLIERUNG EINES TÜRHALTERS VOR

NON DOTATA DI FRENO ANTIVENTO - SIN FRENO ANTI VIENTO - NO ANTI-WIND BRAKE - KEINE BREMSEVENTILE MIT WINDSCHUTZFUNKTION

DISPONIBILE SU RICHIESTA ANCHE NELLA VERSIONE SENZA STOP A 90°. Versione da specificare in fase d'ordine e soggetta a possibili minimi d'ordine. Per ulteriori informazioni contattare l'ufficio commerciale.
 TAMBÉN DISPONIBLE SIN RETENCIÓN A 90°. Se tendrá que especificar en los pedidos y ser objeto de pedido mínimo. Nuestra oficina comercial está a su disposición para ampliar esta o cualquier otra información.
 AVAILABLE IN FURTHER VERSION WITHOUT 90° STOP. It has to be specified on being ordered and could be subjected to minimum quantity order. For further information, please contact the export department.
 ES IST AUCH IN ANDEREN VERSIONE VERFÜGBAR OHNE 90°. Beide sind bei der bestellung anzugeben und könnten eine mindestbestellmenge verlangen. Für weitere informationen setzen sie sich mit unserer exportabteilung im kontakt.

Classificazione secondo normativa - Clasificación según la ley - Classification according to int'l regulation Klassifizierung nach den Vorschriften						
art. 8010JC	UNI EN 1154:2006	3	8	2/5	0	1 4

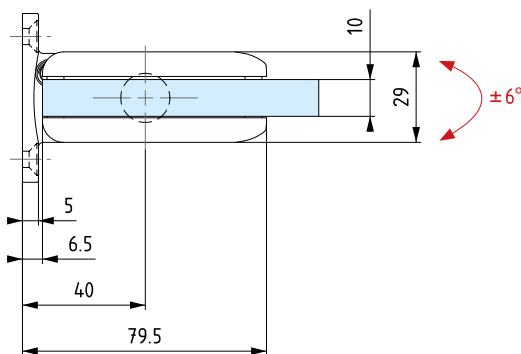
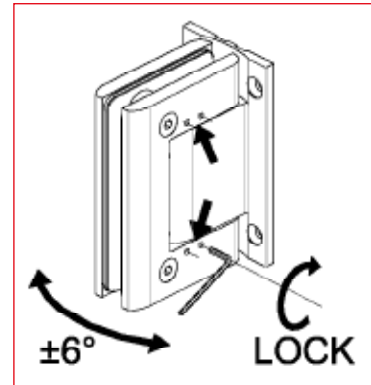
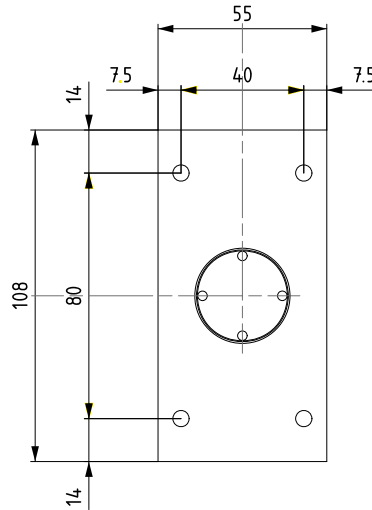
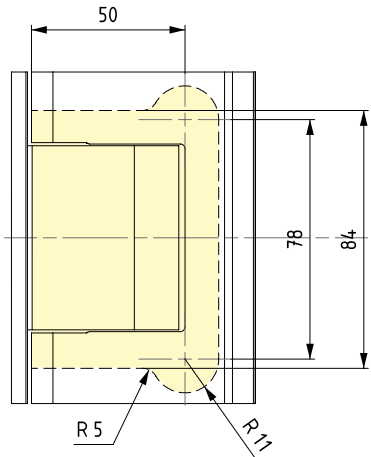

Valvola di regolazione velocità chiusura anta
 Adjuste de velocidad de cierre de la puerta
 Adjustment valve for the door's closing speed
 Regelsventil für die Türschließgeschwindigkeit

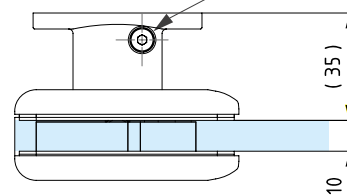

TESTATA 1.000.000 CICLI.
 PROBADA EN 1.000.000 ABERTURAS.
 TESTED FOR 1.000.000 CYCLES.
 GETESTET FÜR 1.000.000 ÖFFNUNGEN.